

Environmental

COMPLIANT WITH
BS EN-12566 Part 3

Envirocare Delta 6

Package Sewage Treatment System

TESTED TO THE
REQUIRED INFLUENT
TEST RANGE OF
300-500mg/l BOD



Sustainable, Reliable, Affordable



Kingspan®

Delta 6

The best designs are the simplest. So if you require trouble free sewage treatment and want to limit your impact on the environment with the highest available standard of treatment, you're sure to be impressed with the new Delta 6.

Fluidised, fixed-film biozones are used as the operating process, resulting in a cleaner, quieter and more efficient treatment plant.

Benefits

- Performance achieved under BS EN 12566-3 test - 12.5mg/l BOD, 21mg/l SS and 7.1mg/l Ammonia
- Unobtrusive below ground installation
- Suitability for varying invert levels
- 450 and 750mm invert options
- Excellent durability
- Low profile results in shallow depth excavation
- Simple maintenance with easy desludging
- Pumped discharge option available

Product specification

Unit Invert Ref. (mm)	A Outlet (mm)	B Overall Length (mm)	C Height (inc. feet) (mm)	D Ducting Invert (mm)	E Overall Diameter (mm)
450	550	2720	1700	250	1530
750	850	2720	2000	550	1530

A new generation of treatment plants for treating domestic sewage waste in a compact system of three separate stages within a 'unitank' design. The fluidised fixed-film biozone process provides an extremely robust means of reducing ammoniacal nitrogen.

Raw sewage flowing to the unit is received in the primary settlement zone. Gross solids settle to the bottom. The residual effluent (supernatant liquor) is displaced from the primary stage into the two-stage biozone.

Flow circulation in the biozone is generated by the effect of a fine bubble system. During several passes through the beds, the supernatant liquor is purified by naturally occurring micro organisms (biomass) that grow on the media. The liquid displaced to the outlet is treated, and known as final effluent.

Complete monitoring and control

Envirocare's high-tech control panel featuring an alarm and digital read-out display, provides the homeowner with an immediate alert should any problem occur.

Supplied as standard throughout the Envirocare sewage treatment plant ranges, the control panel will inform the householder, or maintenance representative on site of any fault via a digital display and fault code. The system also features a highly visible external beacon (optional) as a primary warning.

Alarms are now mandatory for sewage treatment plants in the event of a power failure (ref EA PPG4 and BS EN 12566-3).

Control panel



Alarm beacon

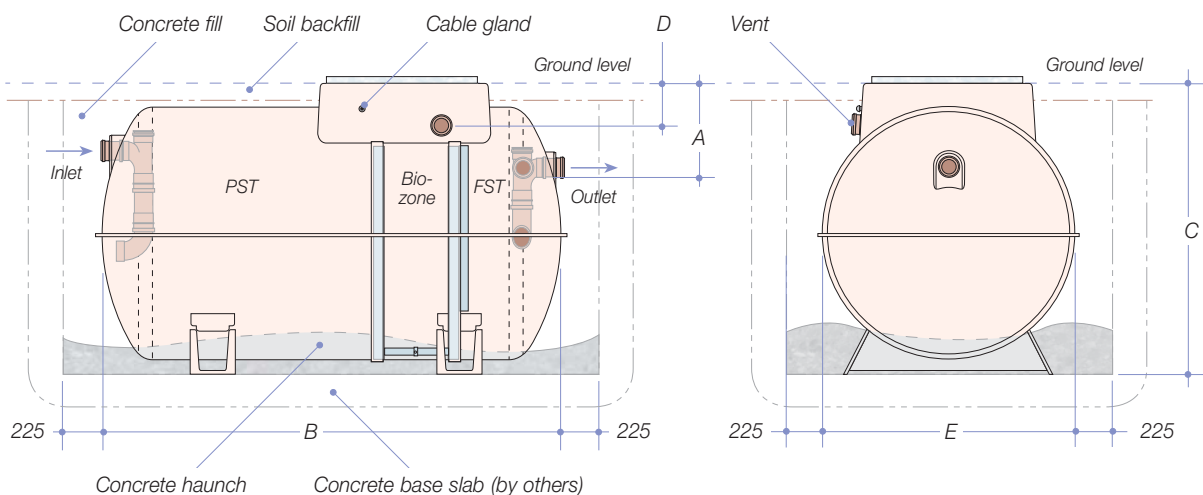

All dimensions in millimetres. PST = Primary Settlement Tank; Biozone = Biological Treatment Zone; FST = Final Settlement Tank.



Easy access for desludging

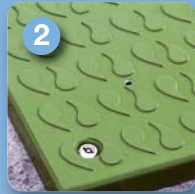

New skid-resistant tread pattern and stainless steel locking device features on the cover



Inlets, outlets and power supply connections are clearly marked on the tank exterior

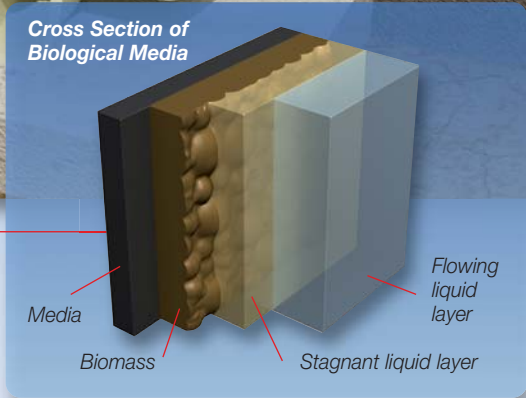
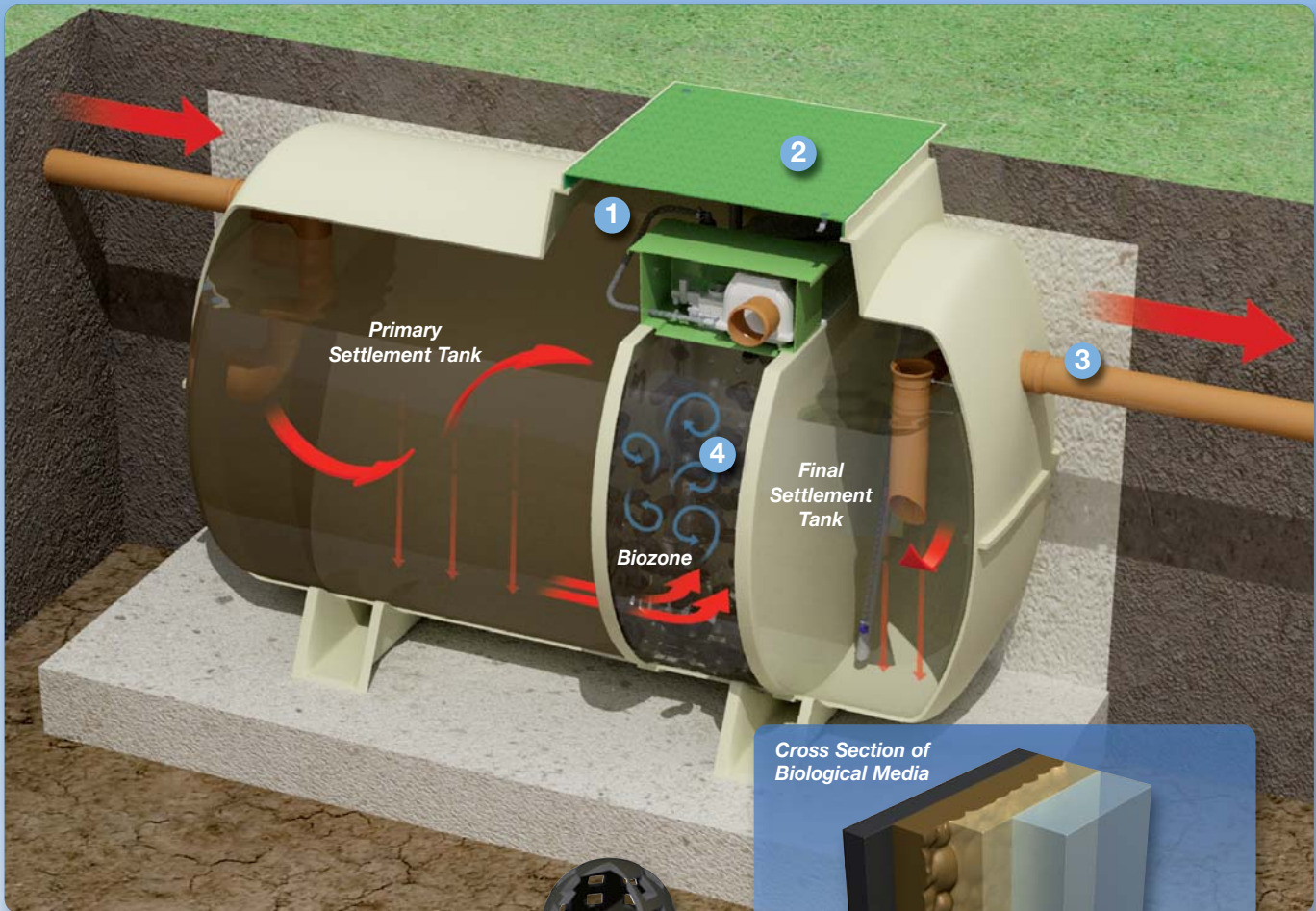

Media

Delta 6's biozone utilises structured plastic media. The media design gives a high surface area which stimulates the growth of bacteria and other organisms (biomass) which actively treat the wastewater.



Pumped Outlet Option

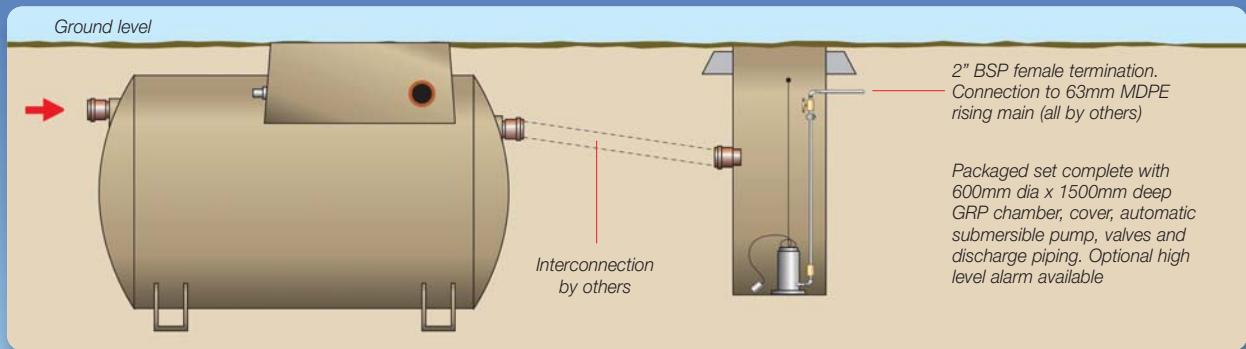

Envirocare Off-Mains Solutions



P6 Sewage Treatment Plants



Delta 6 Sewage Treatment Plants



Attenuation Systems

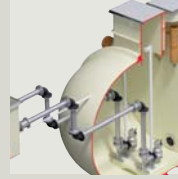

Pumpstore Systems



Pump-Pac Package Pumps

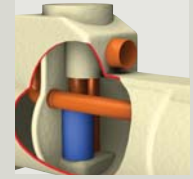

Oil/Water Separators

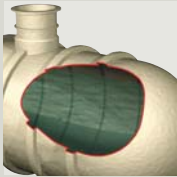

Below Ground Storage Tanks



Grease Traps



Silt Traps



Reed Beds



Rainwater Harvesting

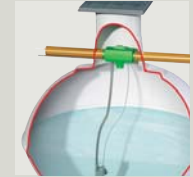

Garden Irrigation

Kingspan Environmental Service

Who better to look after your wastewater product than the people who designed and built it?

Kingspan Environmental have a dedicated service division providing maintenance for wastewater and rainwater products.

Factory trained engineers are available for site visits as part of a planned maintenance contract or on a one-off call out basis.

To find out more about protecting your investment and ensuring peace of mind, contact us on **(NI) 028 302 54077, (IRL) 048 302 54077** or visit us online at www.kingspanenvservice.com



Issue No. 2: September 2010



Envirocare Pollution Control

180 Gilford Road, Portadown, Armagh, BT63 5LF

Lo-Call NI: 0844 225 2775 Lo-Call IRL: 1800 938 388

Tel: +44 (0) 28 3838 4419 Fax: +44 (0) 28 3838 4445
email: sales@envirocare.ie

Visit our website www.envirocare.ie, our company website www.kingspanenv.com, or our group website www.kingspan.com

Envirocare Pollution Control is part of Kingspan Environmental.

